



SCAN-SPEAK

WOOFER

25W/8565-01

Frequency range	19-600 Hz
Equivalent volume, Vas	229 L
Mechanical resistance, Rms	1.00 Ns/m
Effective diaphragm/cone area, Sd	330 cm ²
Voice coil diameter	42 mm
Linear excursion	± 6.5 mm
Nominal impedance	8 ohm
Voice coil resistance	5.5 ohm
Voice coil inductance	0.60 mH
Free air resonance, Fs	19 Hz
Sensitivity, Spl (2.83V,1m)	88.0 dB
Force factor, Bxl	9.30 Tm
Moving mass, Md	47.00 g
Qms	5.60
Qes	0.36
Qts	0.34
Nominal power	100 W
Total weight of driver	2600 g

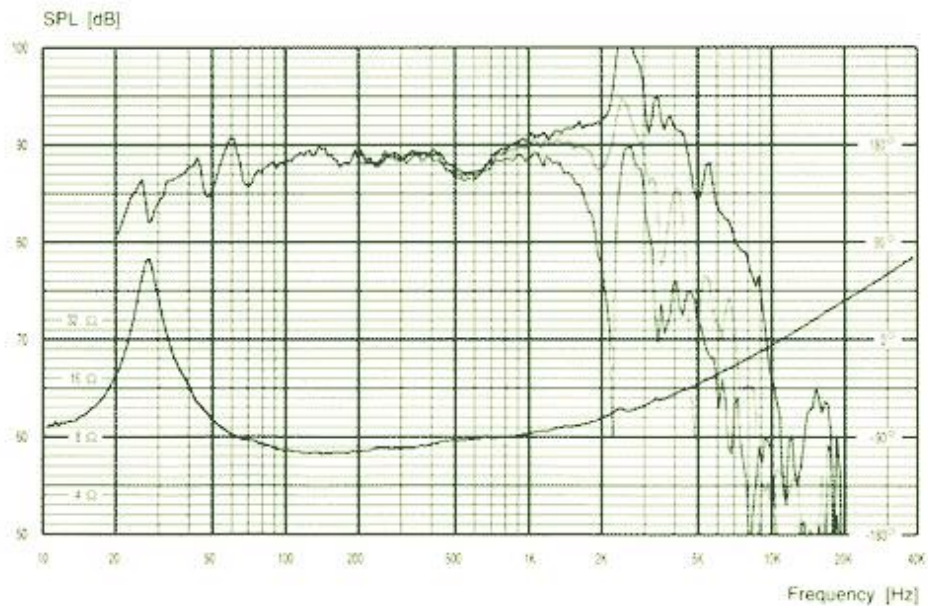
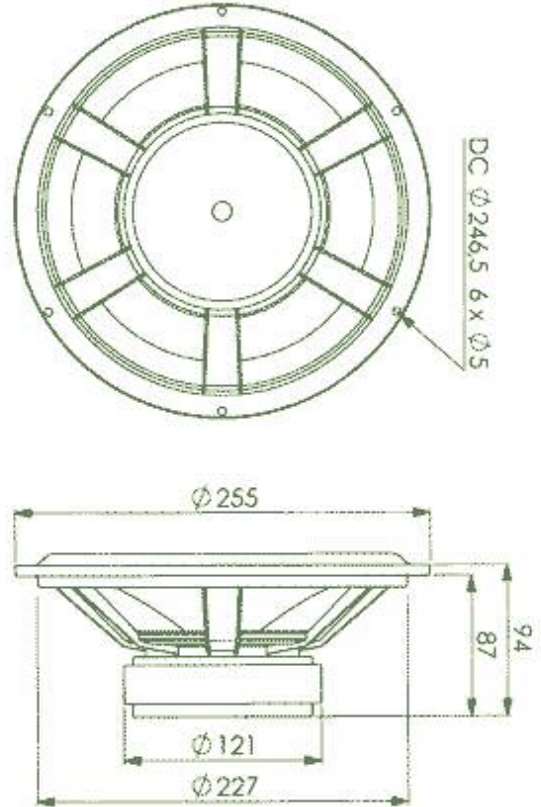

E.B. ACOUSTIC & ELECTRONIC RESEARCH S.R.L.

Via S. Bartolomeo, 10 - 28047 OLEGGIO (NO) Italy Ph. 0039 0321 91430 - Fax 0039 0321 94411

www.ebacoustic.it