

TWEETER

GLADIATOR

GLD32

- * Tweeter ad alta efficienza di concezione PRO.
- * Guida d'onda centrale, per linearizzare la risposta in frequenza.
- * Magnete in ferrite.
- * Chassis in polimero amagnetico.
- * Disponibilità cupola di ricambio

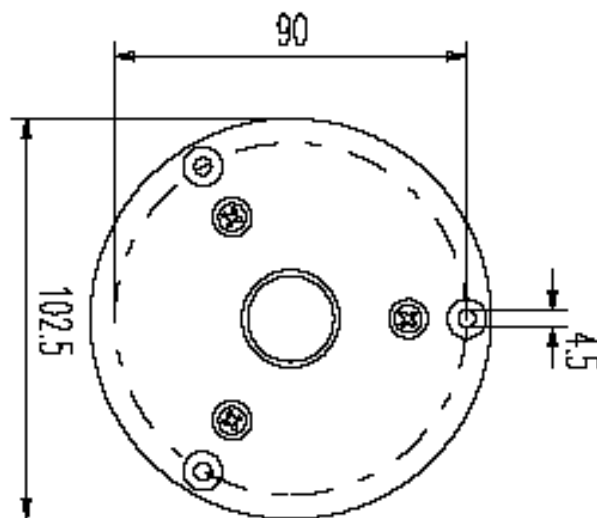
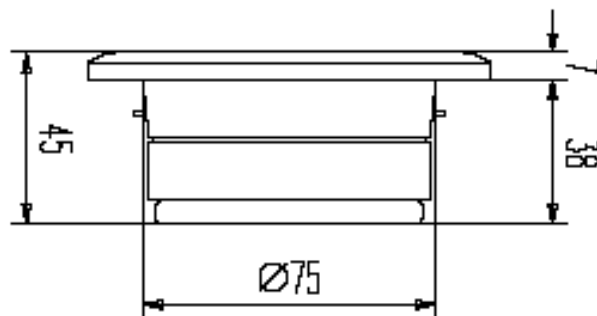

Frequency range	4000-20000	Hz
Equivalent volume, V_{as}	----	L
Effective diaphragm/cone area, S_d	----	cm ²
Voice coil diameter	25.4	mm
Nominal impedance	4	ohm
Voice coil resistance	3.5	ohm
Voice coil inductance	----	mH
Free air resonance, F_s	4500	Hz
Sensitivity, S_{pl} (2.83V,1m)	105	dB
Force factor, B_{xl}	----	N/A
Moving mass, M_d	----	g
Q_{ms}	----	
Q_{es}	----	
Q_{ts}	----	
Nominal power*	25	W
Short term max power*	100	W
Long term max power*	50	W
Recommended crossover	5KHz 12dB/oct.	

