



SUB WOOFER

PXW10

1 Surround- TPR material

2 Gasket- TPR material

3 Cone- PP injected

4 Spider- TPR material

5 Dust Cap- not present

6 Terminal- platinum plated

7 Voice coil- 38x20 mm dual fiberglass former

8 Magnet system vented 8.0mm, gap height

9 Magnet 134x59x24 mm

10 Basket frame steel material

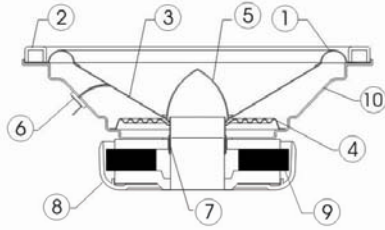

Frequency range	28-2800 Hz
Equivalent volume, Vas	44 L
Compliance, Cms	0,230 mm/N
Mechanical resistance, Rms	4.9 Ns/m
Effective diaphragm/cone area, Sd	363 cm ²
Voice coil diameter	38 mm
Voice coil height	20 mm
Air gap height	8 mm
Linear excursion, Xmax	± 7 mm
Max mechanical excursion	± 14 mm
Nominal impedance (dual)	2 ohm
Voice coil resistance (dual)	1.9 ohm
Voice coil inductance	0,57 mH
Free air resonance, Fs	34 Hz
Sensitivity, Spl (1W/1m)	88 dB
Force factor, Bxl	6.7 Tm
Moving mass, Md	91 g
Qms	4,03
Qes	0,41
Qts	0,38
Nominal power	260 W
Short term max power	520 W
Magnet weight	1467 g
Total weight of driver	4060 g

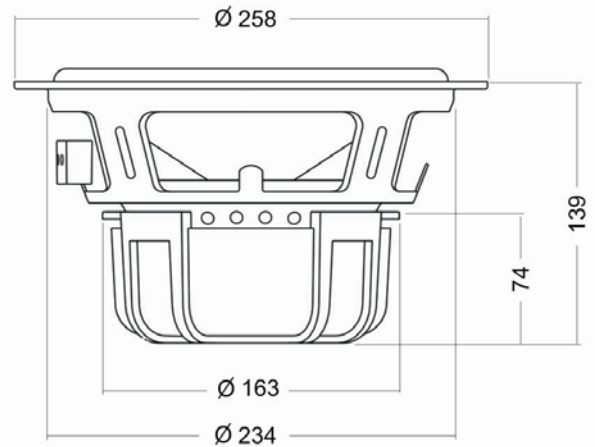
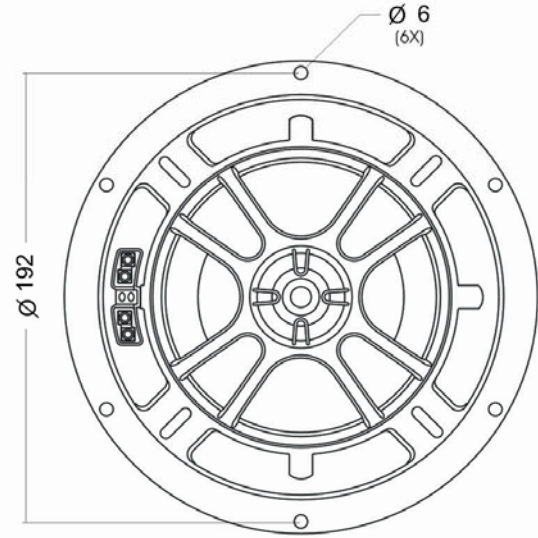

(mm)

SPL vs Freq

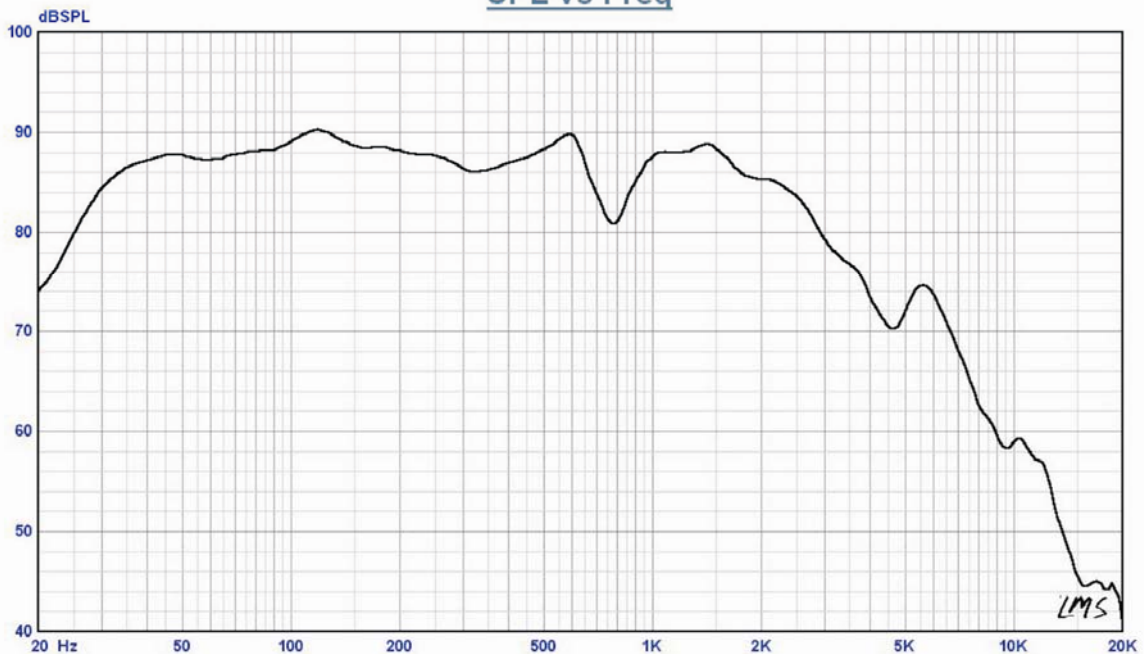

SUB WOOFER PXW10

SEALED ENCLOSURES

Vb (net)	External Dimensions (mm)		
	W	H	D
22.0 lts	340	290	330

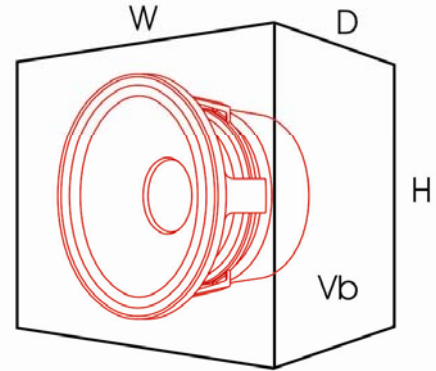

Material - MDF 20mm

VENTED ENCLOSURES

Vb (net)	External Dimensions (mm)				
	W	H	D	Dv	Lv
29.8 lts	340	290	430	3"	360

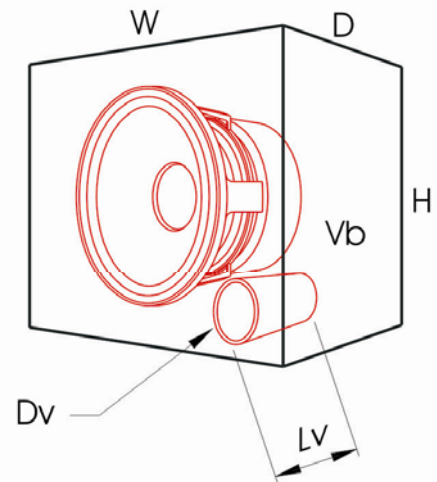

Material - MDF 20mm

E.B. ACOUSTIC & ELECTRONIC RESEARCH

Via S. Bartolomeo , 10 - 28047 OLEGGIO (NO) Italy Ph. 0039 0321 91430 - Fax 0039 0321 94411