

# MIDRANGE

# SQ 4

Cono in carta filmata per colmare i pori della cellulosa.

Elevata linearità della risposta in frequenza e bassa distorsione delle sospensioni.

Bordo in gomma.

Cestello in alluminio con dissipatore di calore per il gruppo magnetico.

Magnete al neodimio.

Insensibile a umidità, temperatura e raggi UV.

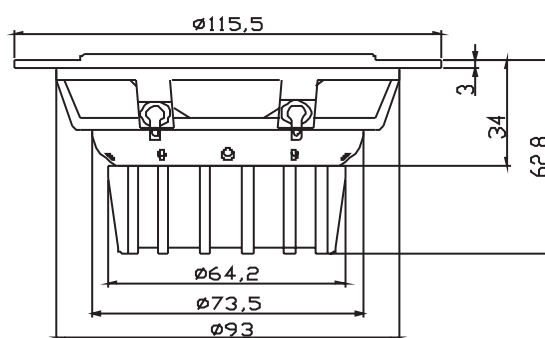
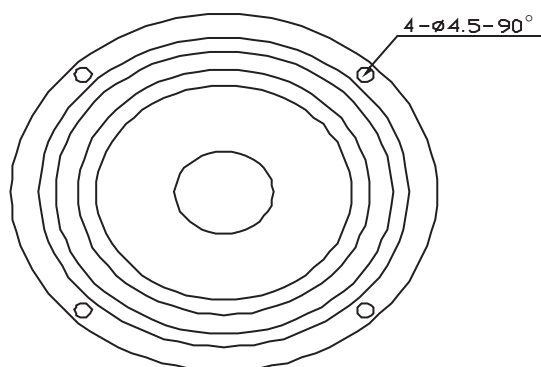

Frequency range	250-15000 Hz
Equivalent volume, Vas	4.1 L
Mechanical resistance, Rms	0.9 Ns/m
Effective diaphragm/cone area, Sd	55 cm <sup>2</sup>
Voice coil diameter	25 mm
Voice coil height	10 mm
Linear excursion	± 4 mm
Nominal impedance	4 ohm
Voice coil resistance	3.6 ohm
Voice coil inductance	0.62 mH
Free air resonance, Fs	70 Hz
Sensitivity, Spl (2.83V,1m)	91 dB
Force factor, Bxl	4.29 Tm
Moving mass, Md	5.16 g
Qms	6.15
Qes	0.46
Qts	0.42
Nominal power*	60 W
Short term max power*	190 W
Long term max power*	120 W
Magnet weight	---
Total weight of driver	---

