

MID-WOOFER

SQ 5

- * Cono in cellulosa trattata corrugata tramite essiccamento naturale per irrigidirne la struttura.
- * Elevata linearità della risposta in frequenza e bassa distorsione delle sospensioni.
- * Bordo in gomma asimmetrico realizzato con tecnologia NR (Non Resonant).
- * Cestello in magnesio pressofuso.
- * Avvolgimento della bobina mobile e sistema magnetico ventilati.
- * Insensibile a umidità, temperatura e raggi UV.

Frequency range	45-8000 Hz
Equivalent volume, Vas	11.0 L
Mechanical resistance, Rms	1.2 Ns/m
Effective diaphragm/cone area, Sd	86.6 cm ²
Voice coil diameter	30.55 mm
Voice coil height	11.9 mm
Linear excursion	± 2.5 mm
Nominal impedance	4 ohm
Voice coil resistance	3.3 ohm
Voice coil inductance	0.60 mH
Free air resonance, Fs	45 Hz
Sensitivity, Spl (2.83V, 1m)	90 dB
Force factor, Bxl	4.20 Tm
Moving mass, Md	11.2 g
Qms	3.00
Qes	0.60
Qts	0.50
Nominal power*	90 W
Short term max power*	360 W
Long term max power*	180 W
Magnet weight	421 g
Total weight of driver	1145 g

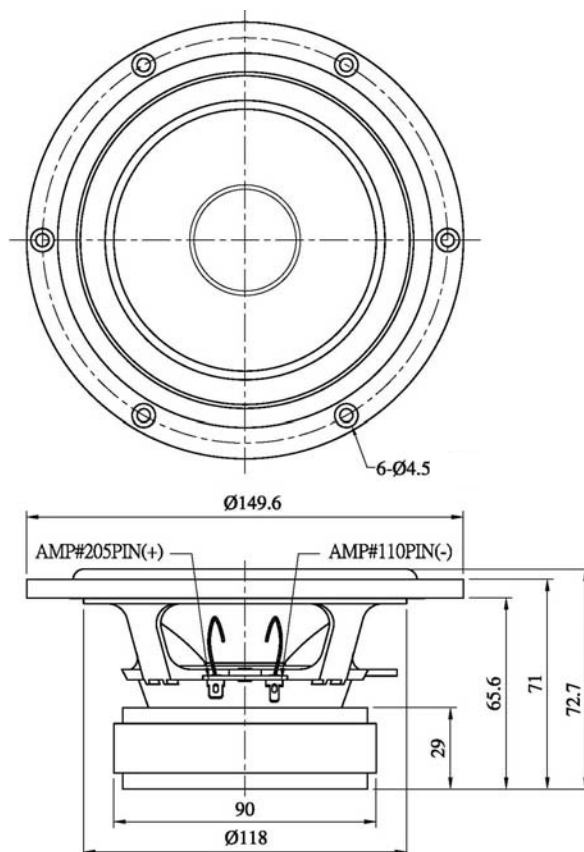

SPL vs Freq



MID-WOOFER

SQ 5

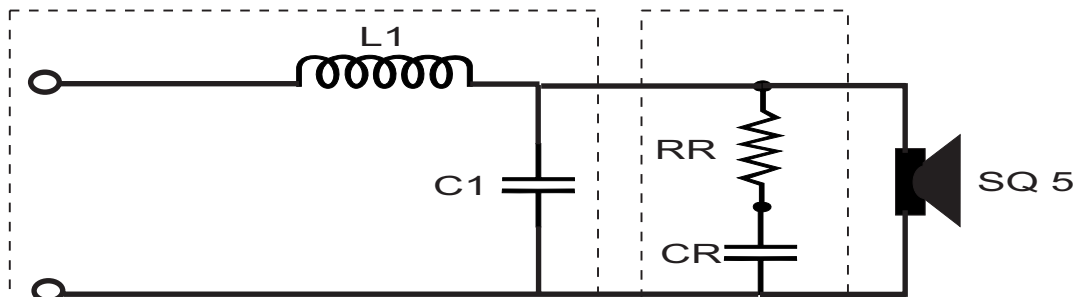

Passa basso

Ft	L1	C1	Ft	L1	C1
350	1,90	100	1500	0,45	22
550	1,25	68	2000	0,34	18
650	1,00	56	2500	0,27	15
800	0,85	47	3000	0,22	12,2
1000	0,65	33	4000	0,18	10

Rifasatore

RR= 3,3
CR= 33

Legenda

Ft frequenza [Hz]

L induttanza [mH]

C capacità [uF]

R resistenza 11W [ohm]



E.B. ACOUSTIC & ELECTRONIC RESEARCH S.R.L.

Via S. Bartolomeo, 10 - 28047 OLEGGIO (NO) Italy Ph. 0039 0321 91430 - Fax 0039 0321 94411

www.ebacoustic.it